



# Listing and Technical Evaluation Report™

Report No: 2311-01



Issue Date: July 15, 2024

Revision Date: July 15, 2024

Subject to Renewal: July 1, 2025

## SaberDrive™ Platinum Truss Screws Used in Beam and Wall Connections

Trade Secret Report Holder:

Midwest Fastener Corporation

Phone: 800-444-7313

Website: [www.fastenerconnection.com](http://www.fastenerconnection.com)

### CSI Designations:

DIVISION: 06 00 00 - WOOD, PLASTICS AND COMPOSITES

Section: 06 00 90 - Wood and Plastic Fastenings

Section: 06 05 23 - Wood, Plastic, and Composite Fastenings

Section: 06 11 00 - Wood Framing

## 1 Innovative Products Evaluated<sup>1</sup>

1.1 SaberDrive Platinum Truss Screws

1.1.1 4 1/2" Truss Screw

1.1.2 6" Truss Screw

## 2 Product Description and Materials

2.1 The innovative products evaluated in this report are shown in **Figure 1**.

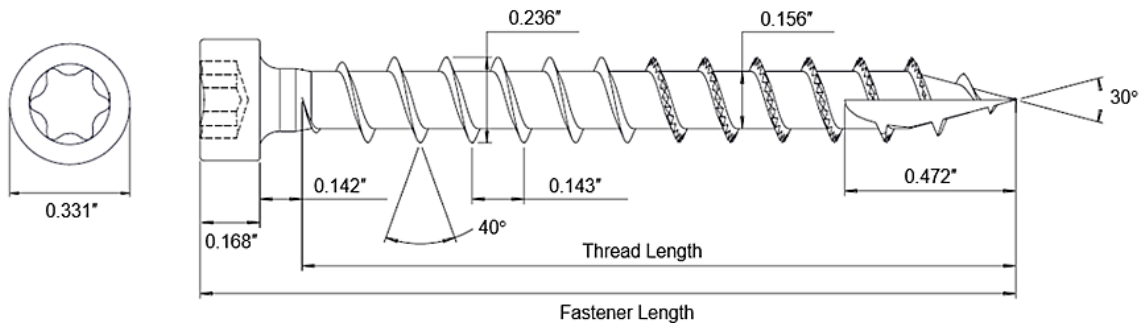

Figure 1. SaberDrive Platinum Truss Screws (Length Not to Scale)



## 2.2 Product Description

- 2.2.1 SaberDrive Platinum Truss Screws are a fully threaded (7 TPI) dowel-type fastener with a cylindrical, Torx-driven head, and a Type 17 self-drilling point.
  - 2.2.1.1 Lead threads are serrated.
  - 2.2.1.2 SaberDrive Platinum Truss Screws are available in tan color.
- 2.2.2 SaberDrive Platinum Truss Screws are available with a proprietary coating system designated as XL1500, meeting the requirements of ASTM G198.

## 2.3 Fastener Material

- 2.3.1 SaberDrive Platinum Truss Screws are made of hardened carbon steel grade 10B21 wire conforming to ASTM A510.
- 2.3.2 Fasteners are subsequently heat-treated and then coated with XL1500.

## 2.4 Corrosion Resistance

- 2.4.1 SaberDrive Platinum Truss Screws may be used where screws are required to exhibit corrosion resistance when exposed to adverse environmental conditions and/or in chemically treated wood, which are subject to the limitations of this report.
  - 2.4.1.1 SaberDrive Platinum Truss Screws have a proprietary XL1500 coating which is equivalent to the protection provided by code-approved hot-dipped galvanized coatings meeting ASTM A153, Class D (IBC Section 2304.10.6 and IRC Section R317.3) when recognized for use by the American Wood Protection Association (AWPA) in untreated wood and Ground Contact – General Use pressure treated wood for exterior, freshwater, general construction applications (i.e., Ground Contact – General Use AWPA UC1 through UC4A).
- 2.4.2 *Pressure-Preservative Treated (PPT) Wood Applications:*
  - 2.4.2.1 SaberDrive Platinum Truss Screws having the proprietary XL1500 coating are recognized for use in PPT lumber provided the conditions set forth by the PPT lumber manufacturer are met, including appropriate strength reductions.
- 2.4.3 *Fire Retardant Treated (FRT) Wood Applications:*
  - 2.4.3.1 SaberDrive Platinum Truss Screws having the proprietary XL1500 coating are recognized for use in FRT lumber provided the conditions set forth by the FRT lumber manufacturer are met, including appropriate strength reductions.

## 2.5 Wood Members

- 2.5.1 Solid sawn wood members connected with SaberDrive Platinum Truss Screws shall consist of lumber species or species combinations having a specific gravity of 0.42 to 0.55.
- 2.5.2 Structural composite lumber (i.e., LVL, LSL, PSL, etc.) connected with SaberDrive Platinum Truss Screws shall be recognized in evaluation reports having published equivalent specific gravities for dowel bearing strength and withdrawal resistance. Equivalent specific gravities for structural composite lumber may be used in the design of connections using the specific gravities of the sawn lumber shown in their respective tables in **Section 6** of this report.



## 2.6 Fastener Specifications

2.6.1 The fasteners evaluated in this report are set forth in **Table 1**.

**Table 1.** Fastener Specifications

Fastener Designation	Head				Length <sup>1</sup> (in)		Diameter (in)		Bending Yield Strength, <sup>3</sup> F <sub>yb</sub> (psi)	Allowable Steel Strength (lb)	
	Style	Drive System	Diameter (in)	Height (in)	Fastener	Thread <sup>2</sup>	Minor	Major		Tensile	Shear <sup>4</sup>
4 1/2" Truss Screw	Cylinder Head	Torx	0.331	0.168	4.5	4.156	0.156	0.236	177,000	1,115	795
6" Truss Screw					6.0	5.651					

SI: 1 in = 25.4 mm, 1 lb = 4.45 N, 1 psi = 0.0069 MPa

- Fastener length is measured from the topside of the head to the tip.
- Fastener is fully threaded. Thread length includes tapered tip.
- Bending yield strength, F<sub>yb</sub>, is determined in accordance with ASTM F1575 using minor thread diameter when fastener is tested in the threaded section.
- Shear strength is determined in accordance with AISI S904 using minor thread diameter when fastener is tested in the threaded section.

2.7 As needed, review material properties for design in **Section 6** and to regulatory evaluation in **Section 8**.

## 3 Definitions

- 3.1 New Materials<sup>2</sup> are defined as building materials, equipment, appliances, systems, or methods of construction not provided for by prescriptive and/or legislatively adopted regulations, known as alternative materials.<sup>3</sup> The design strengths and permissible stresses shall be established by tests<sup>4</sup> and/or engineering analysis.<sup>5</sup>
- 3.2 Duly Authenticated Reports<sup>6</sup> and Research Reports<sup>7</sup> are test reports and related engineering evaluations, which are written by an approved agency<sup>8</sup> and/or an approved source.<sup>9</sup>
- 3.2.1 These reports contain intellectual property and/or trade secrets, which are protected by the Defend Trade Secrets Act (DTSA).<sup>10</sup>
- 3.3 An approved agency is "approved" when it is ANAB ISO/IEC 17065 accredited. DrJ Engineering, LLC (DrJ) is listed in the ANAB directory.
- 3.4 An approved source is "approved" when a professional engineer (i.e., Registered Design Professional) is properly licensed to transact engineering commerce. The regulatory authority governing approved sources is the state legislature via its professional engineering regulations.<sup>11</sup>
- 3.5 Testing and/or inspections conducted for this Duly Authenticated Report were performed by an ISO/IEC 17025 accredited testing laboratory, an ISO/IEC 17020 accredited inspection body, and/or a licensed Registered Design Professional (RDP).
- 3.5.1 The Center for Building Innovation (CBI) is ANAB<sup>12</sup> ISO/IEC 17025 and ISO/IEC 17020 accredited.
- 3.6 The regulatory authority shall enforce<sup>13</sup> the specific provisions of each legislatively adopted regulation. If there is a non-conformance, the specific regulatory section and language of the non-conformance shall be provided in writing<sup>14</sup> stating the nonconformance and the path to its cure.
- 3.7 The regulatory authority shall accept Duly Authenticated Reports from an approved agency and/or an approved source with respect to the quality and manner of use of new materials or assemblies as provided for in regulations regarding the use of alternative materials, designs, or methods of construction.<sup>15</sup>



- 3.8 ANAB is an International Accreditation Forum (IAF) Multilateral Recognition Arrangement (MLA) signatory where recognition of certificates, validation, and verification statements issued by conformity assessment bodies accredited by all other signatories of the IAF MLA with the appropriate scope, shall be approved.<sup>16</sup> Therefore, all ANAB ISO/IEC 17065 Duly Authenticated Reports are approval equivalent.<sup>17</sup>
- 3.9 Approval equity is a fundamental commercial and legal principle.<sup>18</sup>

## 4 Applicable Standards for the Listing; Regulations for the Regulatory Evaluation<sup>19</sup>

### 4.1 Standards

- 4.1.1 *AISI S904: Standard Test Methods for Determining the Tensile and Shear of Screws*
- 4.1.2 *ANSI/AWC NDS: National Design Specification (NDS) for Wood Construction*
- 4.1.3 *ASTM A153: Standard Specification for Zinc Coating (Hot-Dip) on Iron and Steel Hardware*
- 4.1.4 *ASTM A510: Standard Specification for General Requirements for Wire Rods and Coarse Round Wire, Carbon Steel, and Alloy Steel*
- 4.1.5 *ASTM B117: Standard Practice for Operating Salt Spray (Fog) Apparatus*
- 4.1.6 *ASTM D1761: Standard Test Methods for Mechanical Fasteners in Wood and Wood-Based Materials*
- 4.1.7 *ASTM F1575: Standard Test Method for Determining Bending Yield Moment of Nails*
- 4.1.8 *ASTM G85: Standard Practice for Modified Salt Spray (Fog) Testing*
- 4.1.9 *ASTM G198: Standard Test Method for Determining the Relative Corrosion Performance of Driven Fasteners in Contact with Treated Wood*

### 4.2 Regulations

- 4.2.1 *IBC – 15, 18, 21: International Building Code®*
- 4.2.2 *IRC – 15, 18, 21: International Residential Code®*
- 4.2.3 *FBC-B—20, 23: Florida Building Code – Building<sup>20</sup>*
- 4.2.4 *FBC-R—20, 23: Florida Building Code – Residential<sup>20</sup>*

## 5 Listed<sup>21</sup>

- 5.1 Equipment, materials, products or services included in a List published by a nationally recognized testing laboratory (i.e., CBI), approved agency (i.e., CBI and DrJ), and/or approved source (i.e., DrJ) or other organization concerned with product evaluation (i.e., DrJ) that maintains periodic inspection (i.e., CBI) of production of listed equipment or materials, and whose listing states either that the equipment or material meets nationally recognized standards or has been tested and found suitable for use in a specified manner.

## 6 Tabulated Properties Generated from Nationally Recognized Standards

- 6.1 SaberDrive Platinum Truss Screws are fully threaded, dowel-type, self-drilling screws used for wood-to-wood connections.
- 6.2 *Design*
- 6.2.1 Design of SaberDrive Platinum Truss Screws is governed by the applicable code and the provisions for dowel-type fasteners in NDS.
  - 6.2.2 Unless otherwise noted, adjustment of the design stresses for duration of load shall be in accordance with the applicable code.



6.3 Reference Lateral Design Values (Z)

6.3.1 Reference lateral design values (lb) for shear load perpendicular to grain and parallel to grain for SaberDrive Platinum Truss Screws are specified in **Table 2**.

**Table 2.** Reference Lateral Design Values (Z) for Connections in Lumber, lb<sup>1,3,4</sup>

Fastener Designation	Minimum Side Member Thickness (in)	Minimum Main Member Penetration <sup>5</sup> (in)	Wood Species <sup>2</sup> (Specific Gravity)			
			SPF/HF (0.42)		DF-L (0.50)	
			Z <sub>⊥</sub>	Z <sub>  </sub>	Z <sub>⊥</sub>	Z <sub>  </sub>
4 1/2" Truss Screw	1.5	3.0	180	185	185	185
6" Truss Screw	3.0	3.0	195	350	195	350

SI: 1 in = 25.4 mm, 1 lb = 4.45 N

- Reference lateral values apply to two-member single shear connection where both members are of the same specific gravity, and the fastener is oriented perpendicular to grain.
- For wood species with an assigned specific gravity between 0.42 and 0.50, use the tabulated values for specific gravity of 0.42. For wood species with an assigned specific gravity greater than or equal to 0.50, use the tabulated values for specific gravity of 0.50. Tabulated values may also be used for engineered wood products with a corresponding assigned specific gravity.
- Tabulated lateral design values (Z) shall be adjusted by all applicable adjustment factors per NDS Table 11.3.1 for ASD only.
- Z<sub>⊥</sub> = Lateral Design Values Perpendicular to Grain (lb), Z<sub>||</sub> = Lateral Design Values Parallel to Grain (lb)
- Fastener main member penetration is the length embedded in the main member, including the tip.

6.4 Reference Withdrawal Design Values (W) and Head Pull-Through Design Values (P)

6.4.1 Reference withdrawal design values (lb/in) for SaberDrive Platinum Truss Screws are specified in **Table 3**.

**Table 3.** Reference Withdrawal Values (W) – Side Grain Applications, lb/in

Fastener Designation	Penetration <sup>2</sup> (in)	Withdrawal Design Value, <sup>1,3</sup> W (lb/in)	
		Wood Species <sup>4</sup> (Specific Gravity)	
		SPF/HF (0.42)	DF-L (0.50)
4 1/2" and 6" Truss Screw	< 2	215	325
	≥ 2	250	365

SI: 1 in = 25.4 mm, 1 lb = 4.45 N, 1 lb/in = 0.175 kN/m

- Tabulated withdrawal values (W) shall be adjusted by all applicable adjustment factors per NDS Table 11.3.1 for ASD only.
- Minimum fastener penetration into main member of 1" is required. Fastener penetration is the threaded length embedded in the main member, including the tip.
- The design withdrawal value in pounds is equal to  $w_1 + (L_T - 1)w_2$ ; where  $w_1$  = the reference withdrawal value corresponding to 1" penetration,  $L_T$  = embedded thread length (minimum of 1" and maximum of thread length corresponding selected screw's thread length, as listed in **Table 1**), and  $w_2$  = reference withdrawal value corresponding to > 1" penetration.
- For wood species with an assigned specific gravity between 0.42 and 0.50, use the tabulated values for specific gravity of 0.42. For wood species with an assigned specific gravity greater than or equal to 0.50, use the tabulated values for specific gravity of 0.50. Tabulated values may also be used for engineered wood products with a corresponding assigned specific gravity.



6.4.2 Reference head pull-through design values (lb) for SaberDrive Platinum Truss Screws are specified in **Table 4**.

**Table 4.** Reference Pull-Through Design Values (P), lb

Fastener Designation	Wood Side Member Thickness (in)	Pull-Through Design Value, <sup>1</sup> P (lb)	
		Wood Species <sup>2</sup> (Specific Gravity)	
		SPF/HF (0.42)	DF-L (0.50)
4 1/2" and 6" Truss Screw	1.5	445	625

SI: 1 in = 25.4 mm, 1 lb = 4.45 N, 1 lb/in = 0.175 kN/m

1. Tabulated head pull-through values (P) shall be adjusted by all applicable adjustment factors per NDS Table 11.3.1 for ASD only.

2. For wood species with an assigned specific gravity between 0.42 and 0.50, use the tabulated values for specific gravity of 0.42. For wood species with an assigned specific gravity greater than or equal to 0.50, use the tabulated values for specific gravity of 0.50. Tabulated values may also be used for engineered wood products with a corresponding assigned specific gravity.

- 6.5 SaberDrive Platinum Truss Screws are used in the construction of walls that meet the requirements of IBC Section 2308 or IRC Section R602 for the following applications:
- 6.5.1 To attach minimum 1 1/2" thick wood trusses, rafters, floor joists or floor trusses to wood walls, see **Section 6.7** for allowable design loads for top plate to roof truss/rafter/joist connections.
  - 6.5.2 To attach minimum 1 1/2" thick wood gable end trusses to wood walls, see **Section 6.8** for allowable design loads.
  - 6.5.3 To attach bottom plates to rim boards in the construction of walls, see Section 6.9 for allowable design loads.
- 6.6 Allowable design loads are applicable to fasteners installed in accordance with **Section 9**.
- 6.7 Walls shall be constructed in accordance with IBC Section 2308.5.3.2, IRC Section R602.3.2 or an engineered design shall be provided.
- 6.8 SaberDrive Platinum Truss Screws are used in buildings requiring structural design for wind loads in accordance with IBC Section 1609 or wind design in accordance with IRC Section R301.2.1.
- 6.9 SaberDrive Platinum Truss Screws are used in buildings requiring structural design for earthquake loads in accordance with IBC Section 1613 or seismic design in accordance with IRC Section R301.2.2.
- 6.10 *Allowable Design Loads – Roof Truss/Rafter/Joist to Top Plate Connection*
- 6.10.1 Allowable design loads for uplift and lateral resistance for truss, rafter and joist to top plate connections are provided in **Table 5**.
  - 6.10.2 Loads parallel to the wall are labeled F1 and loads perpendicular to the wall are labeled F2. See **Figure 2** for load directions.
  - 6.10.3 Allowable design loads are applicable to fasteners installed in accordance with **Section 9** in double top plate applications.

**Table 5. Allowable Uplift & Lateral Loads for Fasteners in Truss/Rafter/Joist to Top Plate Connections**

Fastener	Min. Penetration into Truss/Rafter/Joist <sup>1</sup> (in)	Top Plate(s)	Fastener Angle to Vertical	Allowable Loads per Fastener <sup>2,3,4,5,6</sup> (lb)								
				SPF/HF (0.42)			DF-L/SCL (0.50)			SP (0.55)		
				Uplift	F1	F2	Uplift	F1	F2	Uplift	F1	F2
4 1/2" Truss Screw	3	Single	0°	670	295	290	750	275	275	750	320	320
6" Truss Screw	3	Double	0°	1,115	560	310	1,055	305	305	1,055	330	330
	2 15/16		22.5° <sup>7</sup>	465	160	255	555	190	305	610	210	330

SI: 1 in = 25.4 mm, 1 lb = 4.448 N

1. Wood truss, rafter or floor joist members shall be a minimum of 2" nominal thickness. Design of truss, rafter or floor joist is by others.
2. Equivalent specific gravity of Structural Composite Lumber (SCL) shall be equal to or greater than the specific gravities provided in this table. Refer to product information from SCL manufacturer.
3. For wood species with an assigned specific gravity between 0.42 and 0.50, use the tabulated values for a specific gravity of 0.42. For wood species with an assigned specific gravity between 0.50 and 0.55, use the tabulated values for a specific gravity of 0.50. For wood species with an assigned specific gravity greater than 0.55, use the tabulated values for a specific gravity of 0.55.
4. For applications involving members with different specific gravities, use the allowable load corresponding to the lowest specific gravity.
5. Includes 1.6 factor for Load Duration increase for wind and seismic. No further increases permitted. Reduce design values for other conditions as applicable.
6. See **Figure 2** for load directions. See **Figure 3** and **Figure 4** for installation details.
7. Install fastener at an upward angle from the vertical of 20° to 30° (22.5° is optimal) or 0° (See **Figure 3** and **Figure 4**). For installation between 20° and 30°, design values for 22.5° may be used.

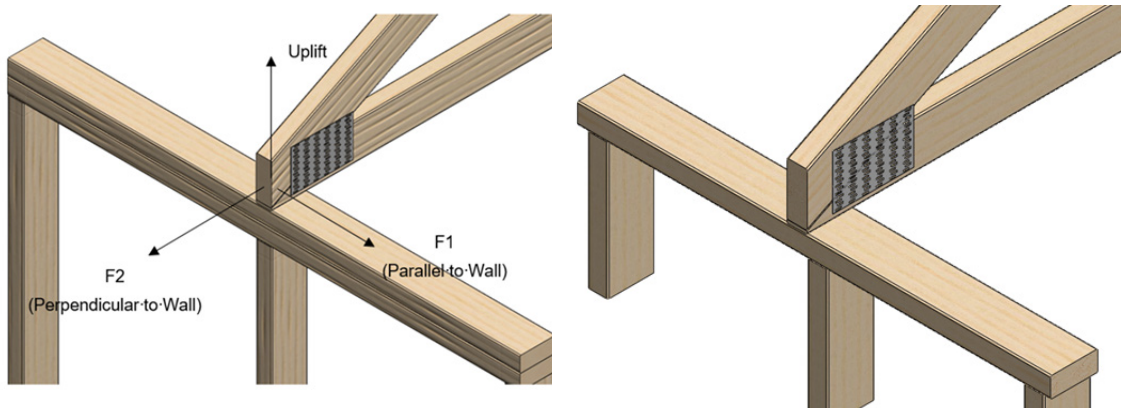

**Figure 2. Uplift and Lateral Load Orientations**

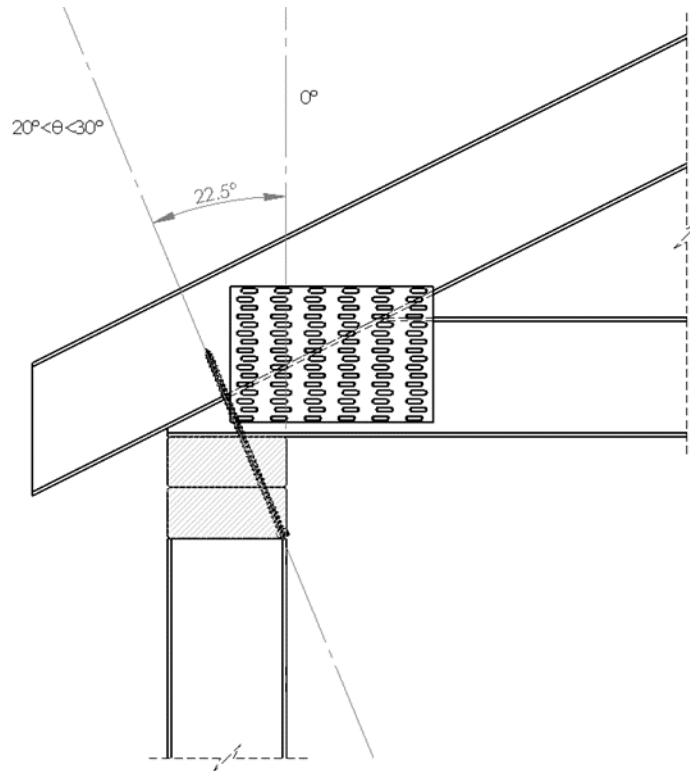

**Figure 3.** Installation of Fasteners at an Angle in Double Top Plate to Truss/Rafter/Joist Applications

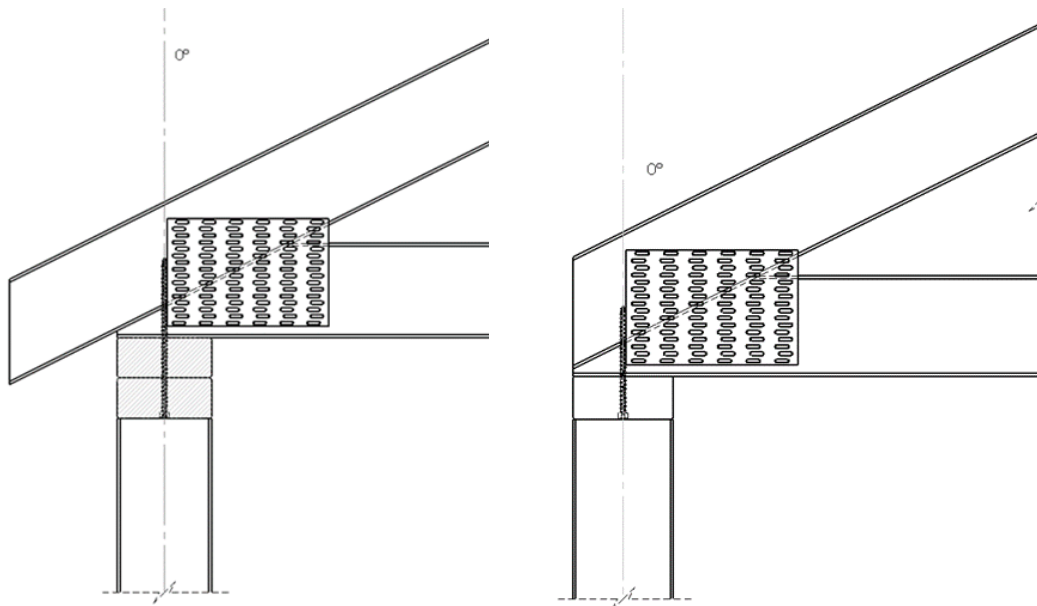

**Figure 4.** Installation of Fasteners in Double Top Plate Perpendicular to Truss/Rafter/Joist Applications



6.11 Allowable Design Loads – Gable End Truss to Top Plate Connection

- 6.11.1 Allowable design loads for uplift and lateral resistance for gable end truss to top plate connections are provided in **Table 6**.
- 6.11.2 Loads parallel to the wall are labeled F1 and loads perpendicular to the wall are labeled F2. See **Figure 5** for load directions.
- 6.11.3 Allowable design loads are applicable to fasteners installed in accordance with Section 9 in single and double top plate applications.

**Table 6.** Allowable Uplift & Lateral Loads for Fasteners in Gable End Truss to Top Plate Connections

Fastener	Min. Penetration into Gable End Truss <sup>1</sup> (in)	Top Plate(s)	Fastener Angle to Vertical	Allowable Loads per Fastener <sup>2,3,4,5,6</sup> (lb)								
				SPF/HF (0.42)			DF-L/SCL (0.50)			SP (0.55)		
				Uplift	F1	F2	Uplift	F1	F2	Uplift	F1	F2
4 1/2" Truss Screw	3.0	Single	0°	670	295	290	750	275	275	750	320	320
6" Truss Screw	3.0	Double	0°	1,115	560	310	1,055	305	305	1,055	330	330

SI: 1 in = 25.4 mm, 1 lb = 4.448 N

1. Gable truss, rafter or floor joist members shall be a minimum of 2" nominal thickness. Design of gable truss, rafter or floor joist is by others.
2. Equivalent specific gravity of Structural Composite Lumber (SCL) shall be equal to or greater than the specific gravities provided in this table. Refer to product information from SCL manufacturer.
3. For wood species with an assigned specific gravity between 0.42 and 0.50, use the tabulated values for a specific gravity of 0.42. For wood species with an assigned specific gravity between 0.50 and 0.55, use the tabulated values for a specific gravity of 0.50. For wood species with an assigned specific gravity greater than 0.55, use the tabulated values for a specific gravity of 0.55.
4. For applications involving members with different specific gravities, use the allowable load corresponding to the lowest specific gravity.
5. Includes 1.6 factor for Load Duration increase for wind and seismic. No further increases permitted. Reduce design values for other conditions as applicable.
6. See **Figure 5** for load directions. See **Figure 6** for installation details.

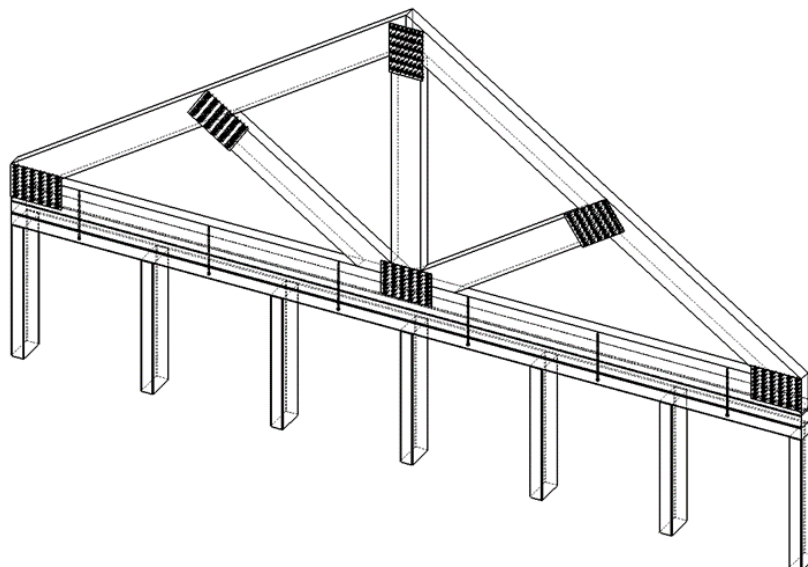

**Figure 5.** Gable End Truss to Top Plate - Uplift and Lateral Load (F1 and F2) Directions

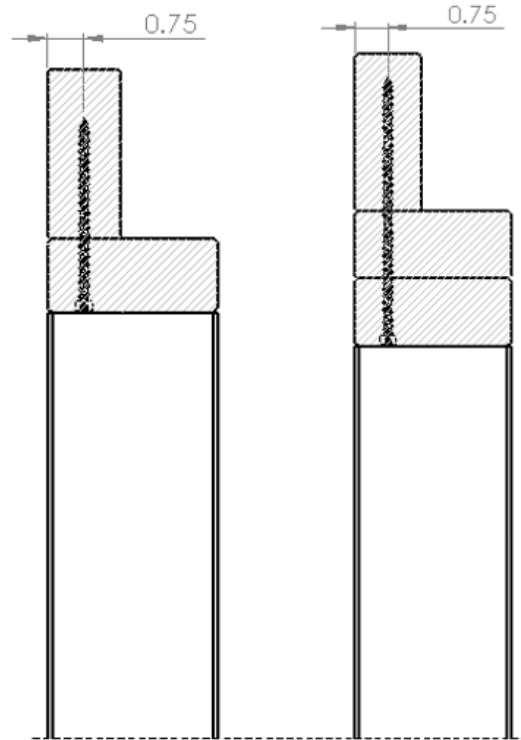

**Figure 6.** Gable End Truss to Top Plate Installation Configuration

6.12 *Allowable Design Loads – Bottom Plate to Rim Board/Ribbon Board Connection*

6.12.1 Allowable design loads for lateral resistance parallel to grain in bottom plate to rim board connections are provided in **Table 7**. The connection configuration is shown in **Figure 7**.

6.12.1.1 A Wood Structural Panel (WSP) up to 1<sup>1</sup>/<sub>8</sub>" thick is permitted between the rim board and the bottom plate, so long as it is independently fastened to the rim board per the building code and the minimum 2" screw penetration is met.

6.12.1.2 Double bottom plates are permitted so long as they are independently fastened per the building code and the minimum 2" screw penetration is met.

6.12.2 Allowable design loads are applicable to fasteners installed in accordance with Section 9.

**Table 7. Allowable Shear Loads Parallel to Grain for Bottom Plate to Rim Board Connections<sup>1,2,3</sup>**

Fastener	Configuration	Min. Penetration into Rim Board (in)	Rim Board Species (Specific Gravity)								
			2x HF/SPF (0.42)			2x DF-L or 1 1/4" SCL (0.50)			2x SP (0.55)		
			Bottom Plate Species (Specific Gravity)								
			HF/SPF (0.42)	DF-L (0.50)	SP (0.55)	HF/SPF (0.42)	DF-L (0.50)	SP (0.55)	HF/SPF (0.42)	DF-L (0.50)	SP (0.55)
<b>Allowable Shear Loads per Fastener, Parallel to Grain (lb)</b>											
4 1/2" Truss Screw	Single Bottom Plate to Rim Board	2.0	150	165	175	160	180	190	165	190	200
6" Truss Screw		3.0	150	165	175	160	180	190	165	190	200
<b>Allowable Uplift Loads per Fastener, Parallel to Grain (lb)</b>											
4 1/2" Truss Screw	Single Bottom Plate to Rim Board	2.0	335	350	350	335	470	470	335	470	470
6" Truss Screw		3.0	335	470	470	335	470	470	335	470	470

SI: 1 in = 25.4 mm, 1 lb = 4.448 N

- For wood species with an assigned specific gravity between 0.42 and 0.50, use the tabulated values for a specific gravity of 0.42. For wood species with an assigned specific gravity between 0.50 and 0.55, use the tabulated values for a specific gravity of 0.50. For wood species with an assigned specific gravity greater than 0.55, use the tabulated values for a specific gravity of 0.55.
- For applications involving members with different specific gravities, use the allowable load corresponding to the lowest specific gravity.
- See **Figure 4** for load directions. See **Figure 5** through **Figure 6** for installation details.
- Tabulated loads are based on a load duration factor of  $C_D = 1.0$ . Loads may be increased for load duration per NDS.

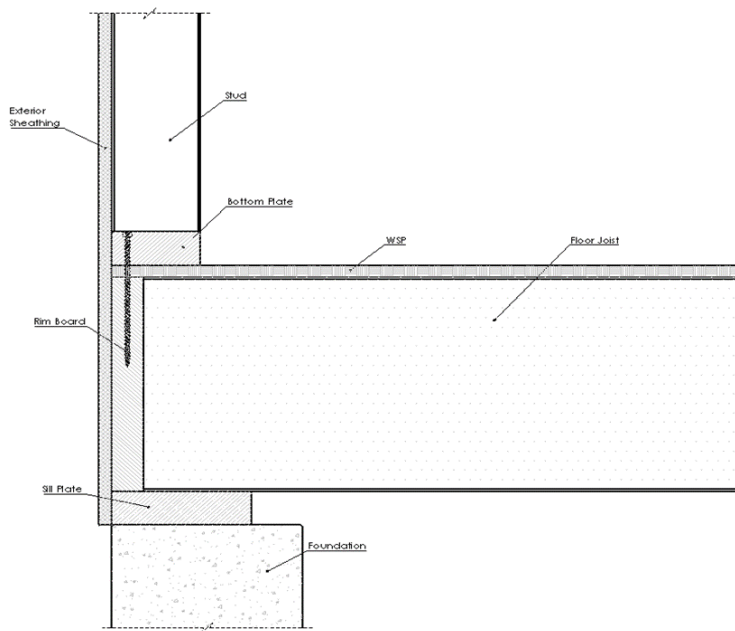

**Figure 7. Fastener in Bottom Plate to Rim Board Connection**



- 6.13 Where it is anticipated that loads will be applied to a single fastener simultaneously in more than one direction, additional evaluation is required to account for the combined effect of these loads using accepted engineering practice.
- 6.14 Where the application falls outside of the performance evaluation, conditions of use and/or installation requirements set forth herein, alternative techniques shall be permitted in accordance with accepted engineering practice and experience. This includes but is not limited to the following areas of engineering: mechanics or materials, structural, building science, and fire science.

## 7 Certified Performance<sup>22</sup>

- 7.1 All construction methods shall conform to accepted engineering practices to ensure durable, livable, and safe construction and shall demonstrate acceptable workmanship reflecting journeyman quality of work of the various trades.<sup>23</sup>
- 7.2 The strength and rigidity of the component parts and/or the integrated structure shall be determined by engineering analysis or by suitable load tests to simulate the actual loads and conditions of application that occur.<sup>24</sup>

## 8 Regulatory Evaluation and Accepted Engineering Practice

- 8.1 SaberDrive Platinum Truss Screws comply with the following legislatively adopted regulations and/or accepted engineering practice for the following reasons:
  - 8.1.1 SaberDrive Platinum Truss Screws were tested and evaluated to determine their structural resistance properties, which were used to develop reference design values for Allowable Stress Design (ASD). The following properties were evaluated:
    - 8.1.1.1 Bending yield in accordance with ASTM F1575
    - 8.1.1.2 Shear strength in accordance with AISI S904
    - 8.1.1.3 Tensile strength in accordance with AISI S904
    - 8.1.1.4 Lateral resistance in accordance with ASTM D1761 and NDS
    - 8.1.1.5 Withdrawal resistance in accordance with ASTM D1761
    - 8.1.1.6 Head pull-through in accordance with ASTM D1761
  - 8.1.2 SaberDrive Platinum Truss Screws were evaluated as an alternative means of attaching:
    - 8.1.2.1 Metal plate connected wood trusses, rafters or floor joists to the tops of walls to provide uplift and lateral load resistance.
    - 8.1.2.2 Gable end to top plates to provide uplift and lateral load resistance.
    - 8.1.2.3 Wall bottom plates to the rim board/ribbon board to provide uplift and lateral load resistance.
  - 8.1.3 Evaluation consisted of the following (where applicable):
    - 8.1.3.1 Withdrawal and head pull-through strength for use as an alternative to toenail connections, metal hurricane and seismic clip/straps or nails in tension (uplift) load applications.
    - 8.1.3.2 Shear strength to resist shear (lateral) loads applied parallel or perpendicular to the wood grain.
    - 8.1.3.3 Shear strength for use as an alternative to toenail connections, hurricane and seismic clip/straps or nails in shear (lateral) load applications either parallel or perpendicular to wood grain.



- 8.1.4 SaberDrive Platinum Truss Screws connections other than those addressed in this section are outside the scope of this report.
- 8.1.5 Corrosion resistance was evaluated in accordance with ASTM B117, ASTM G85 and ASTM G198.
  - 8.1.5.1 Use of fasteners in locations exposed to saltwater or saltwater spray is outside the scope of this report.
- 8.2 Any code compliance issues not specifically addressed in this section are outside the scope of this report.
- 8.3 Any building code, regulation, and/or accepted engineering evaluations (i.e., research reports, Duly Authenticated Reports, etc.) that are conducted for this Listing were performed by DrJ Engineering, LLC (DrJ), an ISO/IEC 17065 accredited certification body and a professional engineering company operated by RDP/approved sources. DrJ is qualified<sup>25</sup> to practice product and regulatory compliance services within its scope of accreditation and engineering expertise, respectively.
- 8.4 Engineering evaluations are conducted with DrJ's ANAB accredited ICS code scope of expertise, which are also its areas of professional engineering competence.
- 8.5 Any regulation specific issues not addressed in this section are outside the scope of this report.

## 9 Installation

- 9.1 Installation shall comply with the approved construction documents, the manufacturer installation instructions, this report and the applicable building code.
- 9.2 In the event of a conflict between the manufacturer installation instructions and this report, the more restrictive shall govern.
- 9.3 *General Installation Procedure*
  - 9.3.1 SaberDrive Platinum Truss Screws shall be installed with a low rpm/high torque electric drill (450 rpm).
  - 9.3.2 SaberDrive Platinum Truss Screws shall be installed with the bottom side of the flat region of the head flush to the surface of the wood member. Fasteners shall not be overdriven.
  - 9.3.3 SaberDrive Platinum Truss Screws shall not be struck with a hammer during installation.
  - 9.3.4 Lead holes are not required but may be used where lumber is prone to splitting in accordance with Section 12.1 of the NDS.



9.4 *Minimum Fastener Spacing, Edge Distance and End Distance*

9.4.1 Minimum requirements for screw spacing edge distance, and end distance shall be in accordance with **Table 8**.

**Table 8.** Screw Spacing, Edge Distance, and End Distance Requirements<sup>1,2</sup>

Connection Geometry	Minimum Spacing (in)
Edge Distance – Load in any direction	1/2
End Distance – Load parallel to grain, towards end	2 <sup>5</sup> / <sub>8</sub>
End Distance – Load perpendicular to grain, away from end	1 <sup>3</sup> / <sub>4</sub>
End Distance – Load perpendicular to grain	1 <sup>3</sup> / <sub>4</sub>
Spacing between Fasteners in a Row – Parallel to grain	2 <sup>5</sup> / <sub>8</sub>
Spacing between Fasteners in a Row – Perpendicular to grain	1 <sup>3</sup> / <sub>4</sub>
Spacing between Rows of Fasteners – In-line	7/ <sub>8</sub>
Spacing between Rows of Fasteners – Staggered <sup>2</sup>	1/2

SI: 1 in = 25.4 mm

- Edge distances, end distances and spacing of fasteners shall be sufficient to prevent splitting of the wood or as shown in this table, whichever is the more restrictive.
- Values for "Spacing between Rows of Fasteners-Staggered" apply where the screws in adjacent rows are offset by one-half of the "Spacing between Fasteners in a Row".

9.5 *Truss/Rafter to Top Plate Connection*

9.5.1 Install fasteners upward through the wall top plates or wood structural framing member at the bottom corner of the top plate(s) and into the center of the wood truss or rafter. The fastener should be installed at an upward angle from the vertical of 20° to 30° (see **Figure 3**) and shall penetrate the wood truss, rafter or joist within 1/4" of the centerline.

9.5.2 Trusses/rafters located between studs may be installed at a 0° angle (see **Figure 4**).

9.5.2.1 Bearing distances between trusses/rafters and studs shall be within the provisions specified in IBC Section 2308.5.3.2 and IRC Section R602.3.2.

9.5.2.2 If the wood truss, rafter or floor joist is located directly over a top plate splice, offset the fastener 1/4" to one side of the splice. Note that the splice may be in either top plate.

9.6 *Gable End Truss to Top Plate Connection*

9.6.1 Install fasteners upward into the center of the gable end truss through the wall top plates or wood structural framing member. The fastener should be installed perpendicular to the face of the top plate between studs (see **Figure 6**) and should penetrate the gable end truss within 1/4" of the centerline.

9.6.1.1 If the screw location for the gable end truss is located directly over a top plate splice or at a bottom chord splice joint, offset the fastener 1<sup>3</sup>/<sub>4</sub>" to one side of the splice.

9.6.1.2 Minimum requirements for fastener spacing, edge distance, and end distance shall be in accordance with **Table 8**.

9.7 *Bottom Plate to Rim Board Connection*

9.7.1 Fastener must be able to be fully embedded at least 2" into the rim board.

9.7.2 Install fasteners downward and perpendicular to the face of the wall bottom plate, a minimum of 1/2" from the outside face of the wall, through the plate and into the rim board (see **Figure 7**).



## 10 Substantiating Data

- 10.1 Testing has been performed under the supervision of a professional engineer and/or under the requirements of ISO/IEC 17025 as follows:
- 10.1.1 Connection design value calculations by DrJ Engineering, LLC in accordance with NDS and accepted engineering practice
  - 10.1.2 Bending yield testing in accordance with ASTM F1575
  - 10.1.3 Shear strength testing in accordance with AISI S904
  - 10.1.4 Tensile strength testing in accordance with AISI S904
  - 10.1.5 Lateral connection testing in accordance with ASTM D1761
  - 10.1.6 Withdrawal testing in accordance with ASTM D1761
  - 10.1.7 Head pull-through testing in accordance with ASTM D1761
  - 10.1.8 Corrosion resistance testing in accordance with ASTM B117, ASTM G85, and ASTM G198
- 10.2 Information contained herein may include the result of testing and/or data analysis by sources that are approved agencies, approved sources, and/or RDPs. Accuracy of external test data and resulting analysis is relied upon.
- 10.3 Where pertinent, testing and/or engineering analysis are based upon provisions that have been codified into law through state or local adoption of regulations and standards. The developers of these regulations and standards are responsible for the reliability of published content. DrJ's engineering practice may use a regulation-adopted provision as the control. A regulation-endorsed control versus a simulation of the conditions of application to occur establishes a new material as being equivalent to the regulatory provision in terms of quality, strength, effectiveness, fire resistance, durability, and safety.
- 10.4 The accuracy of the provisions provided herein may be reliant upon the published properties of raw materials, which are defined by the grade mark, grade stamp, mill certificate, or Duly Authenticated Reports from approved agencies and/or approved sources provided by the supplier. These are presumed to be minimum properties and relied upon to be accurate. The reliability of DrJ's engineering practice, as contained in this Duly Authenticated Report, may be dependent upon published design properties by others.
- 10.5 Testing and engineering analysis: The strength, rigidity, and/or general performance of component parts and/or the integrated structure are determined by suitable tests that simulate the actual conditions of application that occur and/or by accepted engineering practice and experience.<sup>26</sup>
- 10.6 Where additional condition of use and/or regulatory compliance information is required, please search for SaberDrive Platinum Truss Screws on the DrJ Certification website.

## 11 Findings

- 11.1 As outlined in **Section 6**, SaberDrive Platinum Truss Screws have performance characteristics that were tested and/or meet applicable regulations and are suitable for use pursuant to its specified purpose.
- 11.2 When used and installed in accordance with this Duly Authenticated Report and the manufacturer installation instructions, SaberDrive Platinum Truss Screws shall be approved for the following applications:
- 11.2.1 To provide resistance to lateral loads applied to the fastener in a wood-to-wood connection as shown in **Table 2**.
  - 11.2.2 To provide resistance to reference withdrawal loads as shown in **Table 3**.
  - 11.2.3 To provide resistance to head pull-through loads as shown in **Table 4**.
  - 11.2.4 An acceptable means of attaching metal plate connected wood trusses or floor joists to the top of walls to provide uplift and lateral load resistance due to wind and seismic forces as provided in **Table 5**.



- 11.2.5 An acceptable means of attaching gable end trusses to the top of walls to provide uplift and lateral load resistance due to wind in accordance with **Table 6**.
- 11.2.6 An acceptable means of attaching wall bottom plate to rim board/ribbon board to provide lateral load resistance parallel to the bottom plate as provided in **Table 7**.
- 11.3 Unless exempt by state statute, when SaberDrive Platinum Truss Screws are to be used as a structural and/or building envelope component in the design of a specific building, the design shall be performed by an RDP.
- 11.4 Any application specific issues not addressed herein can be engineered by an RDP. Assistance with engineering is available from Midwest Fastener Corporation.
- 11.5 IBC Section 104.11 (IRC Section R104.11 and IFC Section 104.10<sup>27</sup> are similar) in pertinent part states:
  - 104.11 Alternative materials, design and methods of construction and equipment.** The provisions of this code are not intended to prevent the installation of any material or to prohibit any design or method of construction not specifically prescribed by this code. Where the alternative material, design or method of construction is not approved, the building official shall respond in writing, stating the reasons the alternative was not approved.
- 11.6 **Approved:**<sup>28</sup> Building regulations require that the building official shall accept Duly Authenticated Reports.<sup>29</sup>
  - 11.6.1 An approved agency is “approved” when it is ANAB ISO/IEC 17065 accredited.
  - 11.6.2 An approved source is “approved” when an RDP is properly licensed to transact engineering commerce.
  - 11.6.3 Federal law, Title 18 US Code Section 242, requires that where the alternative product, material, service, design, assembly, and/or method of construction is not approved, the building official shall respond in writing, stating the reasons why the alternative was not approved. Denial without written reason deprives a protected right to free and fair competition in the marketplace.
- 11.7 DrJ is a licensed engineering company, employs licensed RDPs and is an ANAB-Accredited Product Certification Body – Accreditation #1131.
- 11.8 Through the IAF Multilateral Agreements (MLA), this Duly Authenticated Report can be used to obtain product approval in any jurisdiction or country because all ANAB ISO/IEC 17065 Duly Authenticated Reports are equivalent.<sup>30</sup>

## 12 Conditions of Use

- 12.1 Material properties shall not fall outside the boundaries defined in **Section 6**.
- 12.2 As defined in **Section 6**, where material and/or engineering mechanics properties are created for load resisting design purposes, the resistance to the applied load shall not exceed the ability of the defined properties to resist those loads using the principles of accepted engineering practice.
- 12.3 Allowable loads reflect dry service conditions.
  - 12.3.1 Sawn lumber members shall have a moisture content no greater than nineteen percent (19%) as specified in Section 4.1.4 of the NDS.
  - 12.3.2 SCL members shall have a moisture content no greater than sixteen percent (16%) as specified in Section 8.1.4 of the NDS.
    - 12.3.2.1 Where SCL is specified in this report, the designated SCL product shall have a published equivalent specific gravity that meets or exceeds the specified specific gravity in the applicable tables in **Section 6**.





- 12.4 When required by adopted legislation and enforced by the building official, also known as the authority having jurisdiction (AHJ) in which the project is to be constructed:
- 12.4.1 Any calculations incorporated into the construction documents shall conform to accepted engineering practice and, when prepared by an approved source, shall be approved when signed and sealed.
  - 12.4.2 This report and the installation instructions shall be submitted at the time of permit application.
  - 12.4.3 These innovative products have an internal quality control program and a third-party quality assurance program.
  - 12.4.4 At a minimum, these innovative products shall be installed per **Section 9** of this report.
  - 12.4.5 The review of this report by the AHJ shall comply with IBC Section 104 and IBC Section 105.4.
  - 12.4.6 These innovative products have an internal quality control program and a third party quality assurance program in accordance with IBC Section 104.4, IBC Section 110.4, IBC Section 1703, IRC Section R104.4, and IRC Section R109.2.
  - 12.4.7 The application of these innovative products in the context of this report is dependent upon the accuracy of the construction documents, implementation of installation instructions, inspection as required by IBC Section 110.3, IRC Section R109.2, and any other regulatory requirements that may apply.
- 12.5 The approval of this report by the AHJ shall comply with IBC Section 1707.1, where legislation states in part, *“the building official shall accept duly authenticated reports from approved agencies in respect to the quality and manner of use of new material or assemblies as provided for in Section 104.11,”* all of IBC Section 104, and IBC Section 105.4.
- 12.6 Design loads shall be determined in accordance with the regulations adopted by the jurisdiction in which the project is to be constructed and/or by the building designer (i.e., owner or RDP).
- 12.7 The actual design, suitability, and use of this report for any particular building, is the responsibility of the owner or the authorized agent of the owner.

### 13 Identification

- 13.1 The innovative products listed in **Section 1.1** are identified by a label on the board or packaging material bearing the manufacturer name, product name, this report number, and other information to confirm code compliance.
- 13.2 Additional technical information can be found at [www.fastenerconnection.com](http://www.fastenerconnection.com).

### 14 Review Schedule

- 14.1 This report is subject to periodic review and revision. For the latest version, visit [drjcertification.org](http://drjcertification.org).
- 14.2 For information on the status of this report, please contact [DrJ Certification](#).

### 15 Approved for Use Pursuant to U.S. and International Legislation Defined in Appendix A

- 15.1 SaberDrive Platinum Truss Screws are included in this report published by an approved agency that is concerned with evaluation of products or services, maintains periodic inspection of the production of listed materials or periodic evaluation of services. This report states either that the material, product, or service meets recognized standards or has been tested and found suitable for a specified purpose. This report meets the legislative intent and definition of being acceptable to the AHJ.



## Appendix A

### 1 Legislation that Authorizes AHJ Approval

- 1.1 **Fair Competition:** State legislatures have adopted Federal regulations for the examination and approval of building code referenced and alternative products, materials, designs, services, assemblies and/or methods of construction that:
  - 1.1.1 Advance innovation
  - 1.1.2 Promote competition so all businesses have the opportunity to compete on price and quality in an open market on a level playing field unhampered by anticompetitive constraints
  - 1.1.3 Benefit consumers through lower prices, better quality, and greater choice
- 1.2 **Adopted Legislation:** The following local, state, and federal regulations affirmatively authorize these innovative products to be approved by AHJs, delegates of building departments, and/or delegates of an agency of the federal government:
  - 1.2.1 Interstate commerce is governed by the Federal Department of Justice to encourage the use of innovative products, materials, designs, services, assemblies, and/or methods of construction. The goal is to “*protect economic freedom and opportunity by promoting free and fair competition in the marketplace.*”
  - 1.2.2 Title 18 US Code Section 242 affirms and regulates the right of individuals and businesses to freely and fairly have new products, materials, designs, services, assemblies, and/or methods of construction approved for use in commerce. Disapproval of alternatives shall be based upon non-conformance with respect to specific provisions of adopted legislation and shall be provided in writing stating the reasons why the alternative was not approved, with reference to the specific legislation violated.
  - 1.2.3 The federal government and each state have a public records act. In addition, each state also has legislation that mimics the federal Defend Trade Secrets Act 2016 (DTSA),<sup>31</sup> where providing test reports, engineering analysis and/or other related IP/TS is subject to prison of not more than ten years<sup>32</sup> and/or a \$5,000,000 fine or 3 times the value of<sup>33</sup> the Intellectual Property (IP) and Trade Secrets (TS).
    - 1.2.3.1 Compliance with public records and trade secret legislation requires approval through the use of Listings, certified reports, Technical Evaluation Reports, Duly Authenticated Reports, and/or research reports prepared by approved agencies and/or approved sources.
  - 1.2.4 For new materials<sup>34</sup> that are not specifically provided for in any regulation, the design strengths and permissible stresses shall be established by tests, where suitable load tests simulate the actual loads and conditions of application that occur.
  - 1.2.5 The design strengths and permissible stresses of any structural material shall conform to the specifications and methods of design using accepted engineering practice.<sup>35</sup>
  - 1.2.6 The commerce of approved sources (i.e., registered PEs) is regulated by professional engineering legislation. Professional engineering commerce shall always be approved by AHJs, except where there is evidence provided in writing, that specific legislation have been violated by an individual registered PE.
  - 1.2.7 The AHJ shall accept Duly Authenticated Reports from approved agencies in respect to the quality and manner of use of new materials or assemblies as provided for in IBC Section 104.11.<sup>36</sup>



- 1.3 **Approved<sup>37</sup> by Los Angeles:** The Los Angeles Municipal Code (LAMC) states in pertinent part that the provisions of LAMC are not intended to prevent the use of any material, device, or method of construction not specifically prescribed by LAMC. The Department shall use Part III, Recognized Standards in addition to Part II, Uniform Building Code Standards of Division 35, Article 1, Chapter IX of the LAMC in evaluation of products for approval where such standard exists for the product or the material and may use other approved standards that apply. Whenever tests or certificates of any material or fabricated assembly are required by Chapter IX of the LAMC, such tests or certification shall be made by a testing agency approved by the Superintendent of Building to conduct such tests or provide such certifications. The testing agency shall publish the scope and limitation(s) of the listed material or fabricated assembly.<sup>38</sup> The Superintendent of Building Approved Testing Agency Roster is provided by the Los Angeles Department of Building and Safety (LADBS). The Center for Building Innovation (CBI) Certificate of Approval License is TA24945. Tests and certifications found in a DrJ Listing are LAMC approved. In addition, the Superintendent of Building shall accept Duly Authenticated Reports from approved agencies in respect to the quality and manner of use of new materials or assemblies as provided for in the California Building Code (CBC) Section 1707.1.<sup>39</sup>
- 1.4 **Approved by Chicago:** The Municipal Code of Chicago (MCC) states in pertinent part that an Approved Agency is a Nationally Recognized Testing Laboratory (NRTL) acting within its recognized scope and/or a certification body accredited by the American National Standards Institute (ANSI) acting within its accredited scope. Construction materials and test procedures shall conform to the applicable standards listed in the MCC. Sufficient technical data shall be submitted to the building official to substantiate the proposed use of any product, material, service, design, assembly, and/or method of construction not specifically provided for in the MCC. This technical data shall consist of research reports from approved sources (i.e., MCC defined Approved Agencies).
- 1.5 **Approved by New York City:** The 2022 NYC Building Code (NYCBC) states in part that an approved agency shall be deemed<sup>40</sup> an approved testing agency via ISO/IEC 17025 accreditation, an approved inspection agency via ISO/IEC 17020 accreditation, and an approved product evaluation agency via ISO/IEC 17065 accreditation. Accrediting agencies, other than federal agencies, must be members of an internationally recognized cooperation of laboratory and inspection accreditation bodies subject to a mutual recognition agreement<sup>41</sup> (i.e., ANAB, International Accreditation Forum [IAF], etc.).
- 1.6 **Approved by Florida:** Statewide approval of products, methods, or systems of construction shall be approved, without further evaluation by:
- 1.6.1 A certification mark or listing of an approved certification agency,
  - 1.6.2 A test report from an approved testing laboratory,
  - 1.6.3 A product evaluation report based upon testing or comparative or rational analysis, or a combination thereof, from an approved product evaluation entity, or
  - 1.6.4 A product evaluation report based upon testing, comparative or rational analysis, or a combination thereof, developed, signed and sealed by a professional engineer or architect, licensed in Florida.
  - 1.6.5 For local product approval, products or systems of construction shall demonstrate compliance with the structural wind load requirements of the Florida Building Code (FBC) through one of the following methods:
    - 1.6.5.1 A certification mark, listing or label from a commission-approved certification agency indicating that the product complies with the code,
    - 1.6.5.2 A test report from a commission-approved testing laboratory indicating that the product tested complies with the code,
    - 1.6.5.3 A product-evaluation report based upon testing, comparative or rational analysis, or a combination thereof, from a commission-approved product evaluation entity which indicates that the product evaluated complies with the code,



- 1.6.5.4 A product-evaluation report or certification based upon testing or comparative or rational analysis, or a combination thereof, developed and signed and sealed by a Florida professional engineer or Florida registered architect, which indicates that the product complies with the code, or
- 1.6.5.5 A statewide product approval issued by the Florida Building Commission.
- 1.6.6 The [Florida Department of Business and Professional Regulation \(DBPR\)](#) website provides a listing of companies certified as a [Product Evaluation Agency](#) (i.e., EVLMiami 13692), a [Product Certification Agency](#) (i.e., CER10642), and as a [Florida Registered Engineer](#) (i.e., ANE13741).
- 1.7 **Approved by Miami-Dade County (i.e., Notice of Acceptance [NOA]):** A Florida statewide approval is an NOA. An NOA is a Florida local product approval. By Florida law, Miami-Dade County shall accept the statewide and local Florida Product Approval as provided for in Florida legislation [553.842](#) and [553.8425](#).
- 1.8 **Approved by New Jersey:** Pursuant to the 2018 Building Code of New Jersey in [IBC Section 1707.1 General](#),<sup>42</sup> it states: “*In the absence of approved rules or other approved standards, the building official shall accept duly authenticated reports from [approved agencies](#) in respect to the quality and manner of use of new materials or assemblies as provided for in the administrative provisions of the Uniform Construction Code (N.J.A.C. 5:23)*”.<sup>43</sup> Furthermore N.J.A.C 5:23-3.7 states: “*Municipal approvals of alternative materials, equipment, or methods of construction.*”
  - 1.8.1 **Approvals:** Alternative materials, equipment, or methods of construction shall be approved by the appropriate subcode official provided the proposed design is satisfactory and that the materials, equipment, or methods of construction are suitable for the intended use and are at least the equivalent in quality, strength, effectiveness, fire resistance, durability, and safety of those conforming with the requirements of the regulations.
    - 1.8.1.1 A field evaluation label and report or letter issued by a nationally recognized testing laboratory verifying that the specific material, equipment, or method of construction meets the identified standards or has been tested and found to be suitable for the intended use, shall be accepted by the appropriate subcode official as meeting the requirements of the above.
    - 1.8.1.2 Reports of engineering findings issued by nationally recognized evaluation service programs such as but not limited to, the Building Officials and Code Administrators (BOCA), the International Conference of Building Officials (ICBO), the Southern Building Code Congress International (SBCCI), the International Code Council (ICC), and the National Evaluation Service, Inc., shall be accepted by the appropriate subcode official as meeting the requirements of the above.
  - 1.8.2 The [New Jersey Department of Community Affairs](#) has confirmed that technical evaluation reports, from any accredited entity listed by [ANAB](#), meets the requirements of item the previous paragraph, given that the listed entities are no longer in existence and/or do not provide “*reports of engineering findings.*”
- 1.9 **Approved by the Code of Federal Regulations Manufactured Home Construction and Safety Standards:** Pursuant to Title 24, Subtitle B, Chapter XX, [Part 3282.14](#)<sup>44</sup> and [Part 3280](#),<sup>45</sup> the Department encourages innovation and the use of new technology in manufactured homes. The design and construction of a manufactured home shall conform to the provisions of Part 3282 and Part 3280 where key approval provisions in mandatory language follow:
  - 1.9.1 “*All construction methods shall be in conformance with accepted engineering practices.*”
  - 1.9.2 “*The strength and rigidity of the component parts and/or the integrated structure shall be determined by engineering analysis or by suitable load tests to simulate the actual loads and conditions of application that occur.*”
  - 1.9.3 “*The design stresses of all materials shall conform to accepted engineering practice.*”



- 1.10 **Approval by US, Local and State Jurisdictions in General:** In all other local and state jurisdictions, the adopted building code legislation states in pertinent part that:
- 1.10.1 For new materials that are not specifically provided for in this code, the design strengths and permissible stresses shall be established by tests.<sup>46</sup>
  - 1.10.2 For innovative alternatives and/or methods of construction, the building official shall accept Duly Authenticated Reports from approved agencies with respect to the quality and manner of use of new materials or assemblies.<sup>47</sup>
    - 1.10.2.1 An approved agency is “approved” when it is ANAB ISO/IEC 17065 accredited. DrJ Engineering, LLC (DrJ) is in the ANAB directory.
    - 1.10.2.2 An approved source is “approved” when an RDP is properly licensed to transact engineering commerce. The regulatory authority governing approved sources is the state legislature via its professional engineering regulations.<sup>48</sup>
  - 1.10.3 The design strengths and permissible stresses of any structural material...shall conform to the specifications and methods of design of accepted engineering practice performed by an approved source.<sup>49</sup>
- 1.11 **Approval by International Jurisdictions:** The USMCA and GATT agreements provide for approval of innovative materials, designs, services, and/or methods of construction through the Agreement on Technical Barriers to Trade and the IAF Multilateral Recognition Arrangement (MLA), where these agreements:
- 1.11.1 State that conformity assessment procedures (i.e., ISO/IEC 17020, 17025, 17065, etc.) are prepared, adopted, and applied so as to grant access for suppliers of like products originating in the territories of other Members under conditions no less favourable than those accorded to suppliers of like products of national origin or originating in any other country, in a comparable situation.
  - 1.11.2 **Approved:** The purpose of the MLA is to ensure mutual recognition of accredited certification and validation/verification statements between signatories to the MLA and subsequently, acceptance of accredited certification and validation/verification statements in many markets based on one accreditation for the timely approval of innovative materials, designs, services, and/or methods of construction.
  - 1.11.3 ANAB is an IAF-MLA signatory where recognition of certificates, validation, and verification statements issued by conformity assessment bodies accredited by all other signatories of the IAF MLA, with the appropriate scope, shall be approved.<sup>50</sup>
  - 1.11.4 Therefore, all ANAB ISO/IEC 17065 Duly Authenticated Reports are approval equivalent.<sup>51</sup>
- 1.12 Approval equity is a fundamental commercial and legal principle.<sup>52</sup>



# Notes

- 1 For more information, visit [drjcertification.org](http://drjcertification.org) or call us at 608-310-6748.
- 2 <https://up.codes/viewer/wyoming/ibc-2021/chapter/17/special-inspections-and-tests#1702>
- 3 Alternative Materials, Design and Methods of Construction and Equipment: The provisions of any regulation code are not intended to prevent the installation of any material or to prohibit any design or method of construction not specifically prescribed by a regulation. Please review <https://www.justice.gov/atr/mission> and <https://up.codes/viewer/colorado/ibc-2021/chapter/1/scope-and-administration#104.11>
- 4 <https://up.codes/viewer/wyoming/ibc-2021/chapter/17/special-inspections-and-tests#1706>:-:text=the%20design%20strengths%20and%20permissible%20stresses%20shall%20be%20established%20by%20tests%20as
- 5 The design strengths and permissible stresses of any structural material shall conform to the specifications and methods of design of accepted engineering practice. <https://up.codes/viewer/wyoming/ibc-2021/chapter/17/special-inspections-and-tests#1706>:-:text=shall%20conform%20to%20the%20specifications%20and%20methods%20of%20design%20of%20accepted%20engineering%20practice
- 6 <https://up.codes/viewer/wyoming/ibc-2021/chapter/17/special-inspections-and-tests#1707.1>:-:text=the%20building%20official%20shall%20accept%20duly%20authenticated%20reports%20from%20approved%20agencies
- 7 <https://up.codes/viewer/wyoming/ibc-2021/chapter/17/special-inspections-and-tests#1703.4.2>
- 8 [https://up.codes/viewer/wyoming/ibc-2021/chapter/2/definitions#approved\\_agency](https://up.codes/viewer/wyoming/ibc-2021/chapter/2/definitions#approved_agency)
- 9 [https://up.codes/viewer/wyoming/ibc-2021/chapter/2/definitions#approved\\_source](https://up.codes/viewer/wyoming/ibc-2021/chapter/2/definitions#approved_source)
- 10 <https://www.law.cornell.edu/uscode/text/18/1832> (b) Any organization that commits any offense described in subsection (a) shall be fined not more than the greater of \$5,000,000 or 3 times the value of the stolen trade secret to the organization, including expenses for research and design and other costs of reproducing the trade secret that the organization has thereby avoided. The federal government and each state have a public records act. To follow DTSA and comply state public records and trade secret legislation requires approval through ANAB ISO/IEC 17065 accredited certification bodies or approved sources. For more information, please review this website: [Intellectual Property and Trade Secrets](#).
- 11 <https://www.nspe.org/resources/issues-and-advocacy/professional-policies-and-position-statements/regulation-professional> AND <https://apassociation.org/list-of-engineering-boards-in-each-state-archive/>
- 12 <https://www.cbiteest.com/accreditation/>
- 13 <https://up.codes/viewer/colorado/ibc-2021/chapter/1/scope-and-administration#104>:-:text=to%20enforce%20the%20provisions%20of%20this%20code
- 14 <https://up.codes/viewer/colorado/ibc-2021/chapter/1/scope-and-administration#104.11>:-:text=Where%20the%20alternative%20material%20design%20or%20method%20of%20construction%20is%20not%20approved%20the%20building%20official%20shall%20respond%20in%20writing%20stating%20the%20reasons%20why%20the%20alternative%20was%20not%20approved AND <https://up.codes/viewer/colorado/ibc-2021/chapter/1/scope-and-administration#105.3.1>:-:text=If%20the%20application%20or%20the%20construction%20documents%20do%20not%20conform%20to%20the%20requirements%20of%20pertinent%20laws%20the%20building%20official%20shall%20reject%20such%20application%20in%20writing%20stating%20the%20reasons%20therefore
- 15 <https://up.codes/viewer/colorado/ibc-2021/chapter/17/special-inspections-and-tests#1707.1>:-:text=the%20building%20official%20shall%20accept%20duly%20authenticated%20reports%20from%20approved%20agencies%20in%20respect%20to%20the%20quality%20and%20manner%20of%20use%20of%20new%20materials%20or%20assemblies%20as%20provided%20for%20in%20Section%20104.11
- 16 <https://iaf.eu/en/about-iaf>
- 17 True for all ANAB accredited product evaluation agencies and all International Trade Agreements.
- 18 <https://www.justice.gov/crt/deprivation-rights-under-color-law> AND <https://www.justice.gov/atr/mission>
- 19 Unless otherwise noted, all references in this Listing are from the 2021 version of the codes and the standards referenced therein. This material, product, design, service and/or method of construction also complies with the 2000-2021 versions of the referenced codes and the standards referenced therein.
- 20 All references to the FBC-B and FBC-R are the same as the 2021 IBC and 2021 IRC unless otherwise noted in the Florida Supplement at the end of this report.
- 21 <https://www.ecfr.gov/current/title-24/subtitle-B/chapter-XX/part-3280#p-3280.2>(Listed%20or%20certified); <https://up.codes/viewer/colorado/ibc-2021/chapter/2/definitions#listed> AND <https://up.codes/viewer/colorado/ibc-2021/chapter/2/definitions#labeled>
- 22 <https://up.codes/viewer/colorado/ibc-2021/chapter/17/special-inspections-and-tests#1703.4>
- 23 <https://www.ecfr.gov/current/title-24/subtitle-B/chapter-XX/part-3280#>:-:text=All%20construction%20methods%20shall%20be%20in%20conformance%20with%20accepted%20engineering%20practices%20to%20insure%20durable%20livable%20and%20safe%20housing%20and%20shall%20demonstrate%20acceptable%20workmanship%20reflecting%20journeyman%20quality%20of%20work%20of%20the%20various%20trades
- 24 <https://www.ecfr.gov/current/title-24/subtitle-B/chapter-XX/part-3280#>:-:text=The%20strength%20and%20rigidity%20of%20the%20component%20parts%20and/or%20the%20integrated%20structure%20shall%20be%20determined%20by%20engineering%20analysis%20or%20by%20suitable%20load%20tests%20to%20simulate%20the%20actual%20loads%20and%20conditions%20of%20application%20that%20occur
- 25 Qualification is performed by a legislatively defined Accreditation Body. ANSI National Accreditation Board (ANAB) is the largest independent accreditation body in North America and provides services in more than 75 countries. DrJ is an ANAB accredited [product certification body](#).
- 26 See Code of Federal Regulations (CFR) Title 24 Subtitle B Chapter XX Part 3280 for definition.
- 27 [2018 IFC Section 104.9](#)
- 28 Approved is an adjective that modifies the noun after it. For example, Approved Agency means that the Agency is accepted officially as being suitable in a particular situation. This example conforms to IBC/IRC/IFC Section 201.4 where the building code authorizes sentences to have an ordinarily accepted meaning such as the context implies.
- 29 <https://up.codes/viewer/wyoming/ibc-2021/chapter/17/special-inspections-and-tests#1707.1>



30 Multilateral approval is true for all ANAB accredited product evaluation agencies and all International Trade Agreements.  
31 <http://www.drjengineering.org/AppendixC> AND <https://www.drjcertification.org/comell-2016-protection-trade-secrets>  
32 <https://www.law.cornell.edu/uscode/text/18/1832#:~:text=imprisoned%20not%20more%20than%2010%20years>  
33 <https://www.law.cornell.edu/uscode/text/18/1832#:~:text=Any%20organization%20that,has%20thereby%20avoided>  
34 <https://up.codes/viewer/wyoming/ibc-2021/chapter/17/special-inspections-and-tests#1706.2>  
35 IBC 2021, Section 1706.1 Conformance to Standards  
36 IBC 2021, Section 1707 Alternative Test Procedure, 1707.1 General  
37 See Section 11 for the distilled building code definition of **Approved**  
38 Los Angeles Municipal Code, SEC. 98.0503. TESTING AGENCIES  
39 <https://up.codes/viewer/california/ca-building-code-2022/chapter/17/special-inspections-and-tests#1707.1>  
40 New York City, The Rules of the City of New York, § 101-07 Approved Agencies  
41 New York City, The Rules of the City of New York, § 101-07 Approved Agencies  
42 <https://up.codes/viewer/new-jersey/ibc-2018/chapter/17/special-inspections-and-tests#1707.1>  
43 <https://www.nj.gov/dca/divisions/codes/codreg/ucc.html>  
44 <https://www.ecfr.gov/current/title-24/subtitle-B/chapter-XX/part-3282/subpart-A/section-3282.14>  
45 <https://www.ecfr.gov/current/title-24/subtitle-B/chapter-XX/part-3280>  
46 IBC 2021, Section 1706 Design Strengths of Materials, 1706.2 New Materials. Adopted law pursuant to IBC model code language 1706.2.  
47 IBC 2021, Section 1707 Alternative Test Procedure, 1707.1 General. Adopted law pursuant to IBC model code language 1707.1.  
48 <https://www.nspe.org/resources/issues-and-advocacy/professional-policies-and-position-statements/regulation-professional> AND <https://apassociation.org/list-of-engineering-boards-in-each-state-archive/>  
49 IBC 2021, Section 1706 Design Strengths of Materials, Section 1706.1 Conformance to Standards Adopted law pursuant to IBC model code language 1706.1.  
50 <https://iaf.nu/en/about-iaf-mla/#:~:text=it%20is%20required%20to%20recognise%20certificates%20and%20validation%20and%20verification%20statements%20issued%20by%20conformity%20assessment%20bodies%20accredited%20by%20all%20other%20signatories%20of%20the%20IAF%20MLA%2C%20with%20the%20appropriate%20scope>  
51 True for all ANAB accredited product evaluation agencies and all International Trade Agreements.  
52 <https://www.justice.gov/crt/deprivation-rights-under-color-law> AND <https://www.justice.gov/atr/mission>